

TECHNICAL DATA SHEET

**D - 100 - 07
CYLINDRICAL THRU BOLT
PREPARATION**

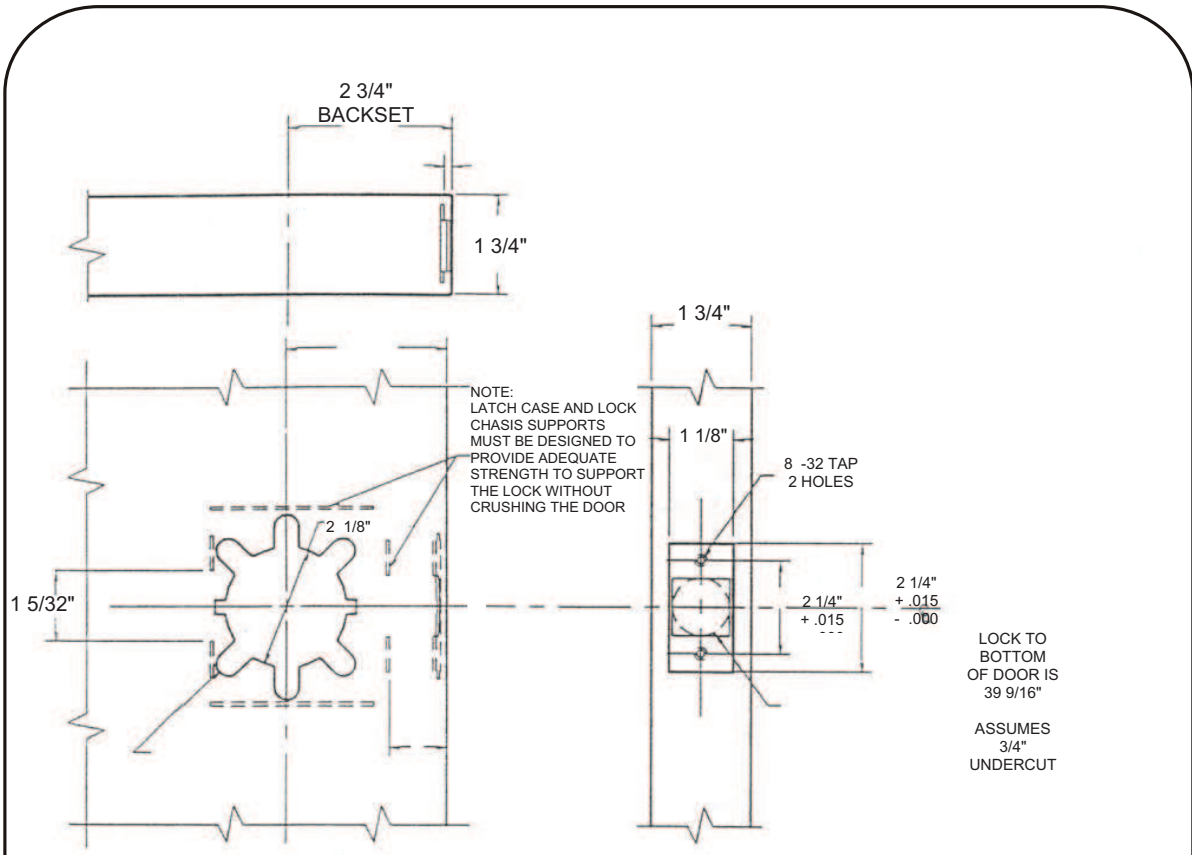

DOOR FACE DETAIL

DOOR EDGE DETAIL

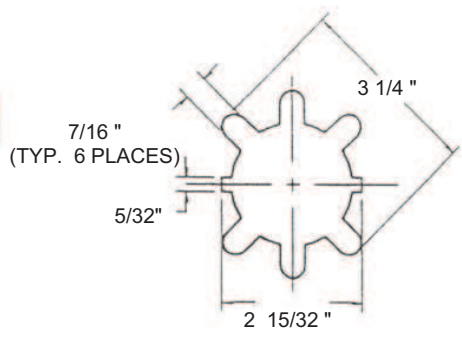

NOTE:

REINFORCEMENT IS BOX TYPE CONSTRUCTION
MFG. FROM 20 GA STEEL WELDED TO LOCK CHANNEL

ANSI A115-18

Issue Date: January 2006
REVISED : 02/01/2009

